

Moen Burp! Assembly

You should have:

- 6 long legs with casters
- 2 short legs with casters
- 2 legs accompanied by flanges and casters
- 2 black plastic leg spacer tubes to fit over leg
- 2 mounting plates
- 50 screws for mounting plates
- 50 lock washers

1. Attach the 2 short legs to the “body” of the table with lock washers and screws.

2. Fasten 3 legs (without flanges) to each “wing” in the locations marked by an “x” on the drawing using lock washers and screws.

3. Fasten the two mounting plates to the “wings”.

4. Place the table body upright (you now need 2 people) - place a black plastic spacer over a hole.

5. Fasten one of the remaining 2 legs (those with flanges) in the location marked by an “o” in the drawing by guiding it up through the hole and spacer, and rotating it into the mounting plate.

6. Repeat step 4 with the other wing.

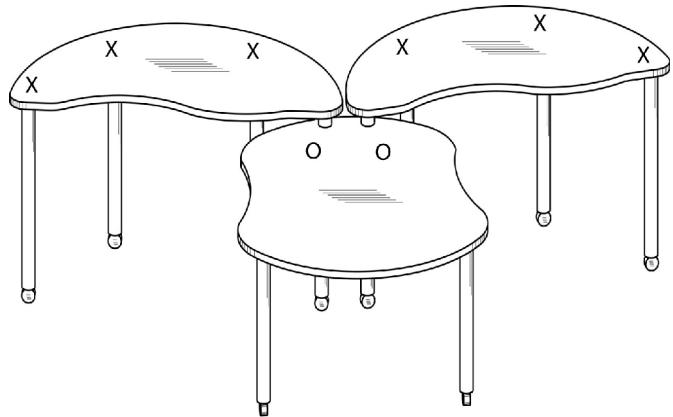

FIG. 3

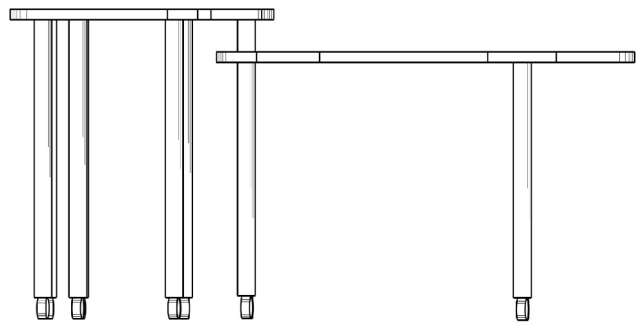

FIG. 4